

Rev/No	Revision note	Date	Signature	Checked
1	DIMENSIONS UPDATED AS ORIGINALLY ISSUED INCORRECTLY.	01/02/2010	DK	AL
2	DIMENSIONS UPDATED.	26/04/2011	DK	LB

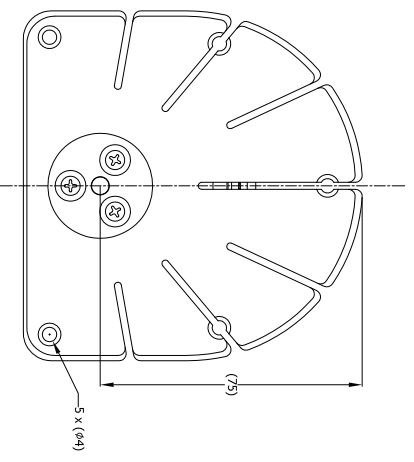
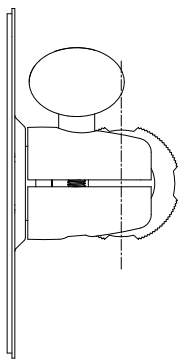
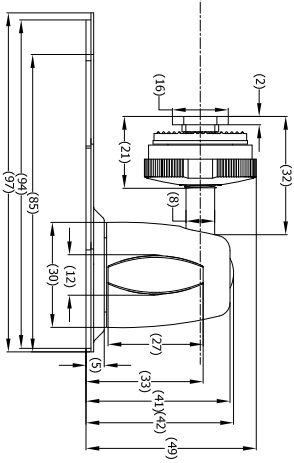
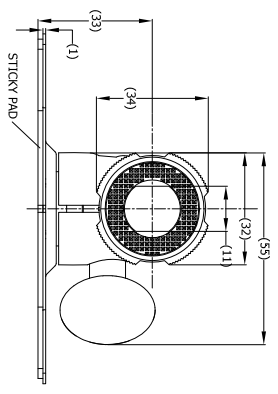
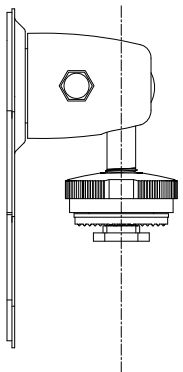
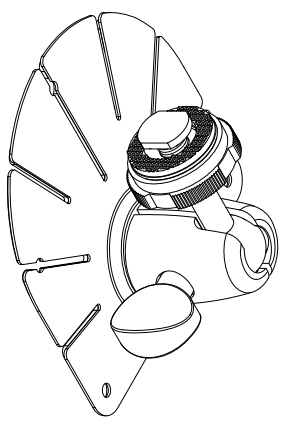
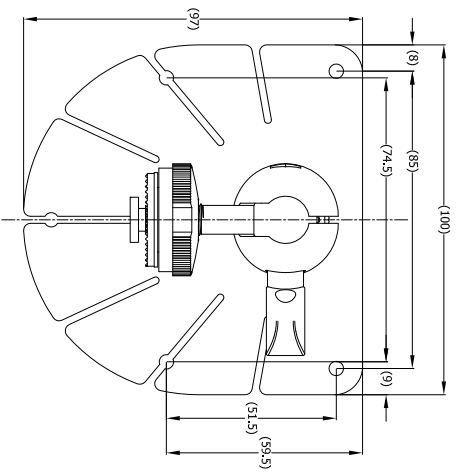

**NOTES:**  
**MATERIAL IS STEEL**  
**FINISH IS PAINTED BLACK**  
**DIMENSIONS IN MM**

PROPRIETARY NOTICE  
 THIS DESIGN AND TECHNICAL INFORMATION APPEARING ON THIS DRAWING IS THE PROPERTY OF BRIGADE ELECTRONICS PLC, AND IS DISCLOSED IN CONFIDENCE. IT IS NOT TO BE COPIED, REPRODUCED, REVEALED TO OR APPROPRIATE BY OTHERS, EITHER IN WHOLE OR IN PART, WITHOUT THE EXPRESS WRITTEN CONSENT OF BRIGADE ELECTRONICS PLC.

ASSEMBLY PLANT REF: TBD

Item#	Quantity	Title/Name, designation, material, dimension etc	Article No./Reference
Designed by		Checked by	Date
MOUTIER		DKERAI	02/09/09
Approved by		SMATTREWS	
BRIGADE ELECTRONICS		BMN-015 (#3148A)	
BE-000895-02-09		Edition	
		A	
		Sheet	
		1/1	